

EPOS

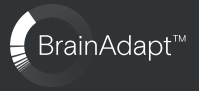

# IMPACT 700 Series

Ensure customer satisfaction on every call with a headset that delivers rich, natural sound no matter the level of background noise. Three digital microphones built on EPOS BrainAdapt™ provide industry-leading voice pickup to let your agents be heard.



reddot winner 2024



# Key Features

## Stay Comfortable Throughout the Day

Lightweight headset for next level comfort with soft, leatherette earpads crafted for all-day wear to ensure agent well-being.

## Built for laser-sharp focus in busy work environments

Stay focused on the customer with passive noise dampening, incoming speech clarity, and ActiveGard™ acoustic shock protection.

## Ergonomic inline controller for frictionless calls

Effortlessly answer calls, mute the mic, and change volume with an intuitive inline controller that's always where you need it.

## Backed by exclusive 3-year extended warranty

Get peace of mind with a product that is engineered to withstand prolonged heavy use and truly built to last for years.

## Industry-leading voice pickup for natural-sounding calls

Enjoy exceptional call clarity with three beamforming mics powered by EPOS AI™ that suppress noise and transmit natural voice.

# What's in the Box



Carry Pouch



Compliance Sheet

Quick Guide

Safety Guide



IMPACT 700



USB-C to USB-A Adaptor

# How to Use the IMPACT 700

## Adjusting and wearing the headset

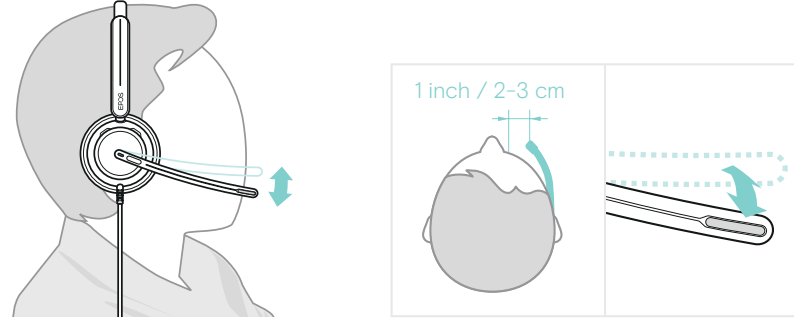

## Connecting

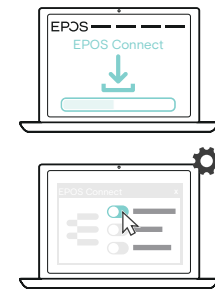
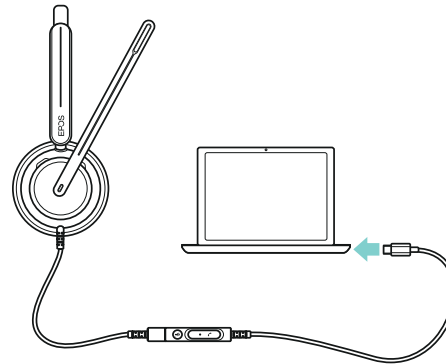

## Adjusting the volume

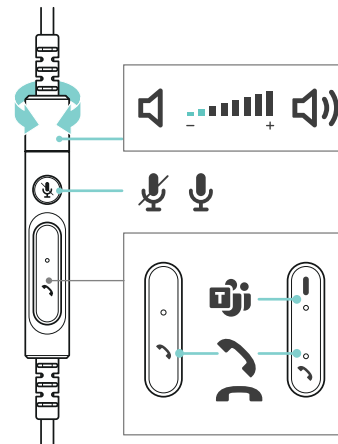

## Mute/unmute



## Accept/end a call

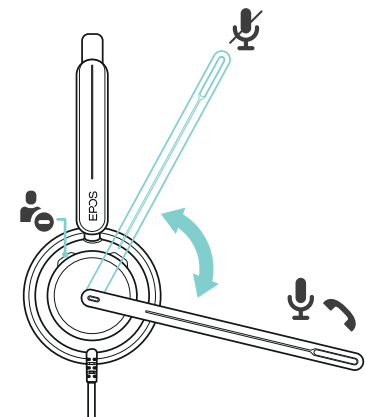

# Additional benefits & features



## Controller that's always at hand

Just 25 cm from the headset, the inline controller never gets lost or fumbled.



## Practical mute alert

LED on the tip of the mic flashes to notify you if you try to speak while muted.



## Busylight for fewer interruptions

360-degree busylight clearly signals to others when you're not to be disturbed.



## Intuitive smart features

Mute/unmute or answer calls by moving the boom arm or taking the headset on/off.



## Integrates perfectly with EPOS Manager

Analyze, manage, and update devices remotely with the free, secure tool.



## ActiveGard™ for hearing safety

ActiveGard™ technology prevents loud spikes and supports noise-at-work compliance.



## Sidetone encourages softer conversations

Audible voice feedback helps agents speak in a softer, more pleasant tone.



## Multiple connection options

Includes a USB-C to USB-A adapter for flexible, future-proof ease of use.



## Guaranteed compatibility

Optimized for Contact Center platforms and certified for leading UC providers.



## Compact and easy to transport

The slim headset folds flat to fit neatly in the compact storage pouch.

---

# Product data

1/3

## General

Wearing style	On-ear, headband. Single- and double-sided variants
Headset weight	Double-sided: 115 g Single-sided: 80 g
Connectivity	USB-C & USB-A (USB adaptor included)
Cable length	1.8 m   5.9 ft
Warranty	3 years

## Audio

Microphone technology	Adaptive beamforming microphone system powered by EPOS AI™
Speaker frequency response	20 Hz - 20 KHz
Microphone type	3 digital MEMS
Microphone frequency response	100 Hz - 16 KHz
Bandwidth in call mode (Speaker + Mic)	Super Wideband

---

# Product data

2/3

---

## Products variants

---

IMPACT 730/730T

---

IMPACT 760/760T

---

## Software

---

EPOS devices can be managed with following Software solutions:

---

EPOS Connect

---

EPOS Manager

---

---

## What's in the box

---

Single-sided headset, wired USB-C with inline controller, USB-C to A adaptor, Carry pouch, Quick Guide, Safety & Compliance sheet.

---

Double-sided headset, wired USB-C with inline controller, USB-C to A adaptor, Carry pouch, Quick Guide, Safety & Compliance sheet.

---

Conduct firmware updates and configure headsets for personal audio preferences.

EPOS Connect works for Windows, Mac® and VDI/Thin client environments: [eposaudio.com/software-epos-connect](https://eposaudio.com/software-epos-connect)

---

Manage, update and configure EPOS audio devices from any location.

For both cloud and on-premises solutions: [eposaudio.com/software-epos-manager](https://eposaudio.com/software-epos-manager)

---

# Product data

3/3

Product	Connects to	Certifications	EAN code	UPC code
IMPACT 730 Art. no. 1001211	USB-C / USB-A	Compatible with leading contact center platforms and UC providers	57 14708 01016 6	8 40064 41016 8
IMPACT 730T Art. no. 1001212	USB-C / USB-A	Compatible with leading contact center platforms and UC providers, Certified for Microsoft Teams	57 14708 01017 3	8 40064 41017 5
IMPACT 760 Art. no. 1001213	USB-C / USB-A	Compatible with leading contact center platforms and UC providers	57 14708 01018 0	8 40064 41018 2
IMPACT 760T Art. no. 1001214	USB-C / USB-A	Compatible with leading contact center platforms and UC providers, Certified for Microsoft Teams	57 14708 01019 7	8 40064 41019 9



---

# Accessories & Spares

1/1

Product	Variant number	Variant Short Description	EAN code	UPC code
MPACT 700 ear pads	1001230	Leatherette ear pads - 2 pcs.	57 14708 01037 1	8 40064 41037 3

---

---

# Appendix

1/1

## Additional product data

---

EPOS ActiveGard® technology

---

Protects users against acoustic injury caused by sudden sound burst on the line

---

EU Noise at Work limiter\*

---

Enhanced audio protection preventing listening fatigue, average 85 dB over a workday

---

EPOS BrainAdapt™

---

For a clear and natural listening experience

---

Busylight

---

Yes, 360-degree

---

Inline Controller

---

Yes, ultra-small formfactor, placed 25 cm from headset

---

Smart operation

---

Yes, mute/unmute or answer calls by moving the boom arm or taking the headset on/off

---

Earpad size

---

Ø65 mm

---

Earpads

---

Memory foam with leatherette

---

Mute alert

---

Yes, visual and audible notification if talking while muted

---

Incoming Speech clarity

---

Yes, automatically boost the high frequencies in the incoming voice signal if the speech is muffled

---

Call volume normalizer

---

Yes, automatically amplify the voice signal if the incoming speech is low

---

\* In compliance with EU Noise at Work legislation (Directive 2003/10/EC), that sets limits for two types of noise in the workplace: Acoustic burst and Sustained noise.